

Block Diagram of System/RF Blocks

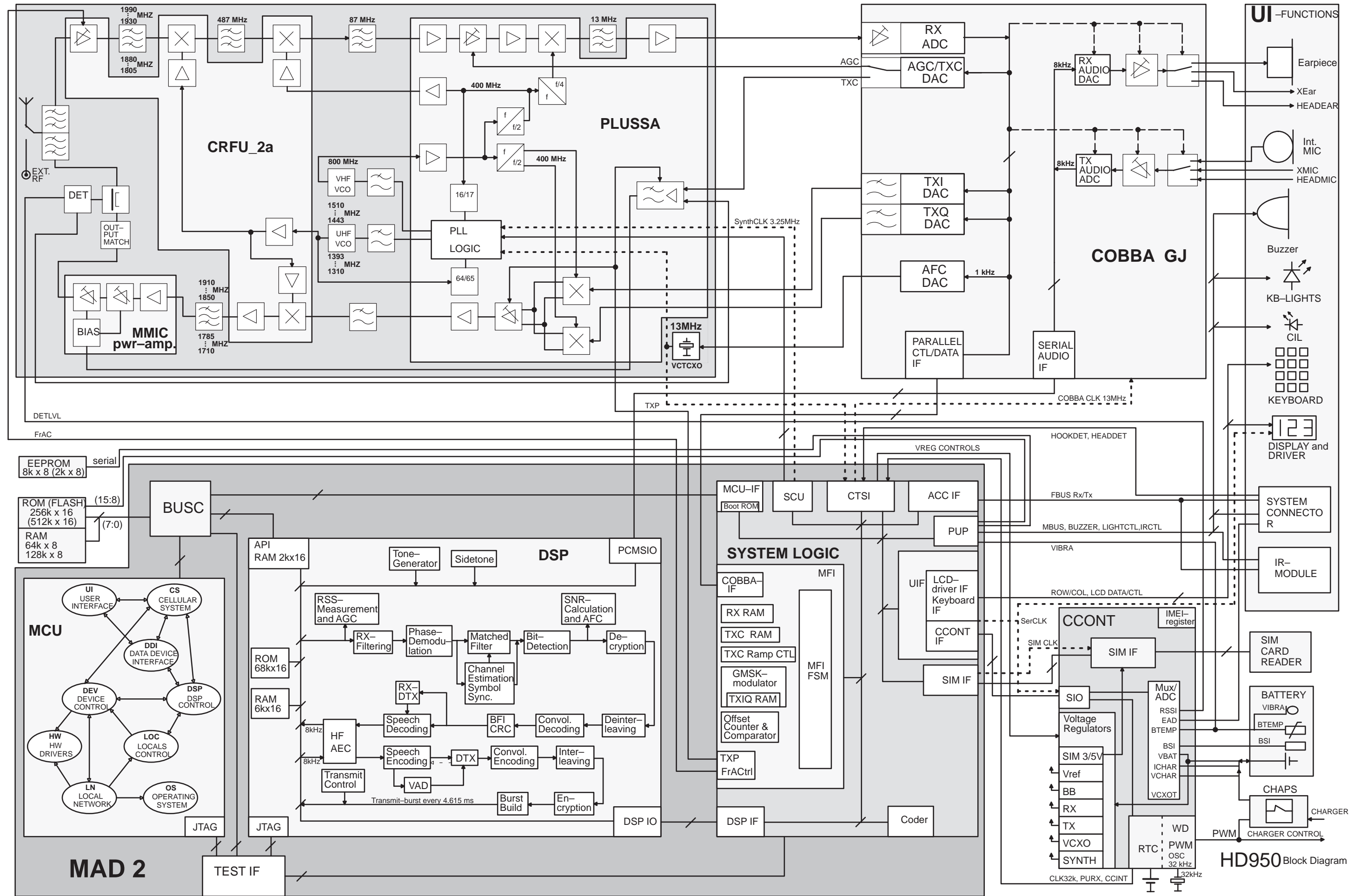

HD950 Block Diagram

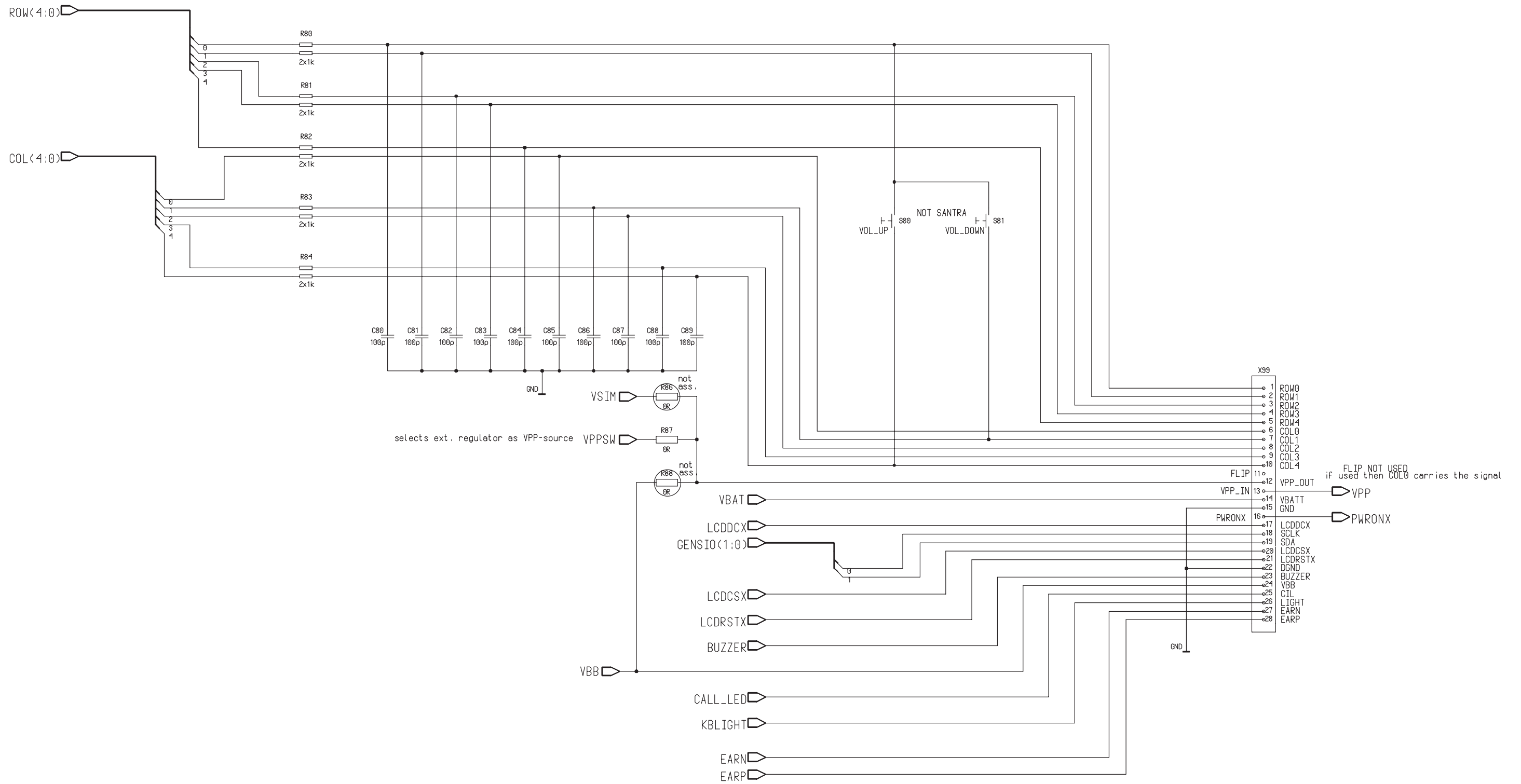

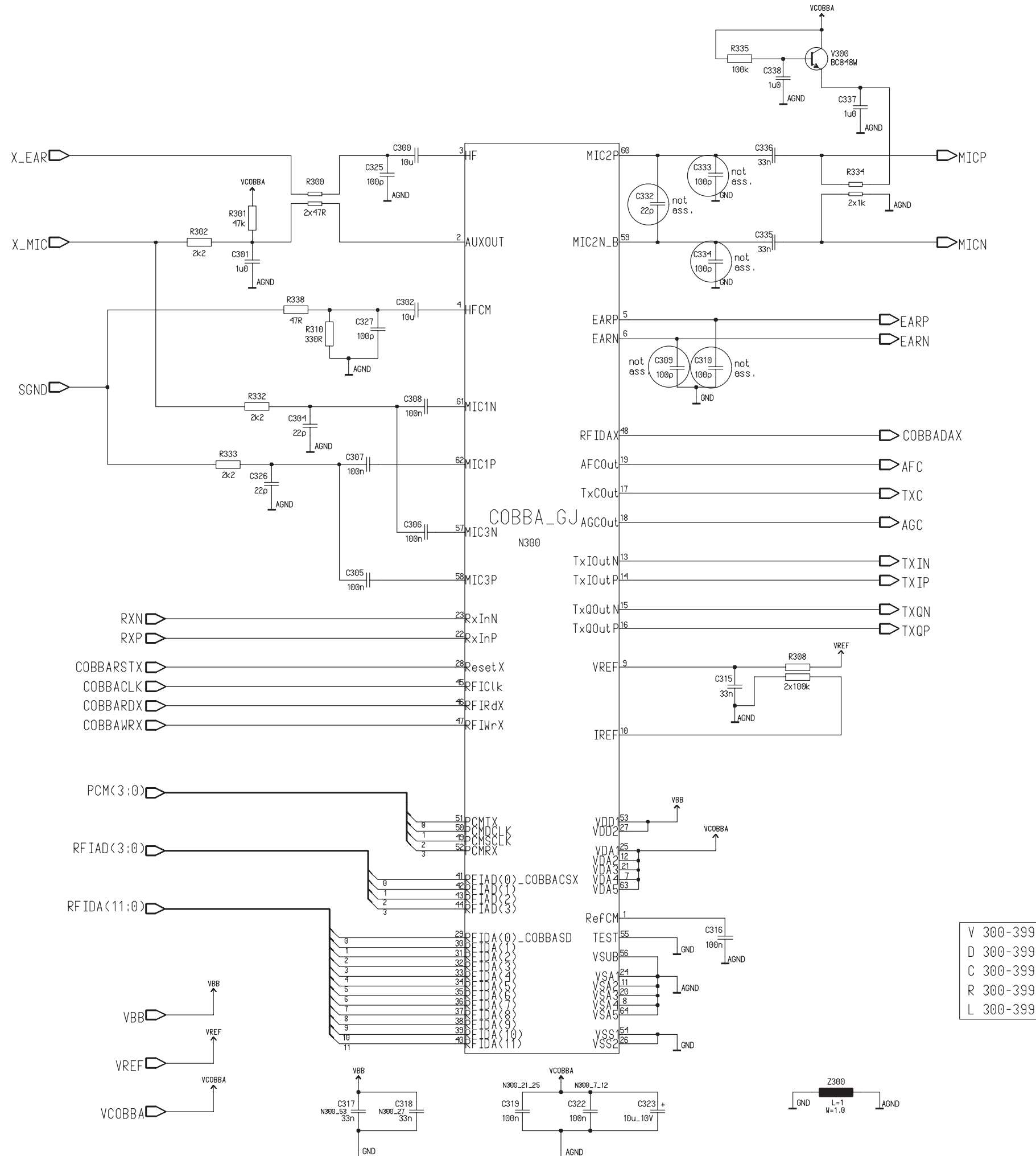

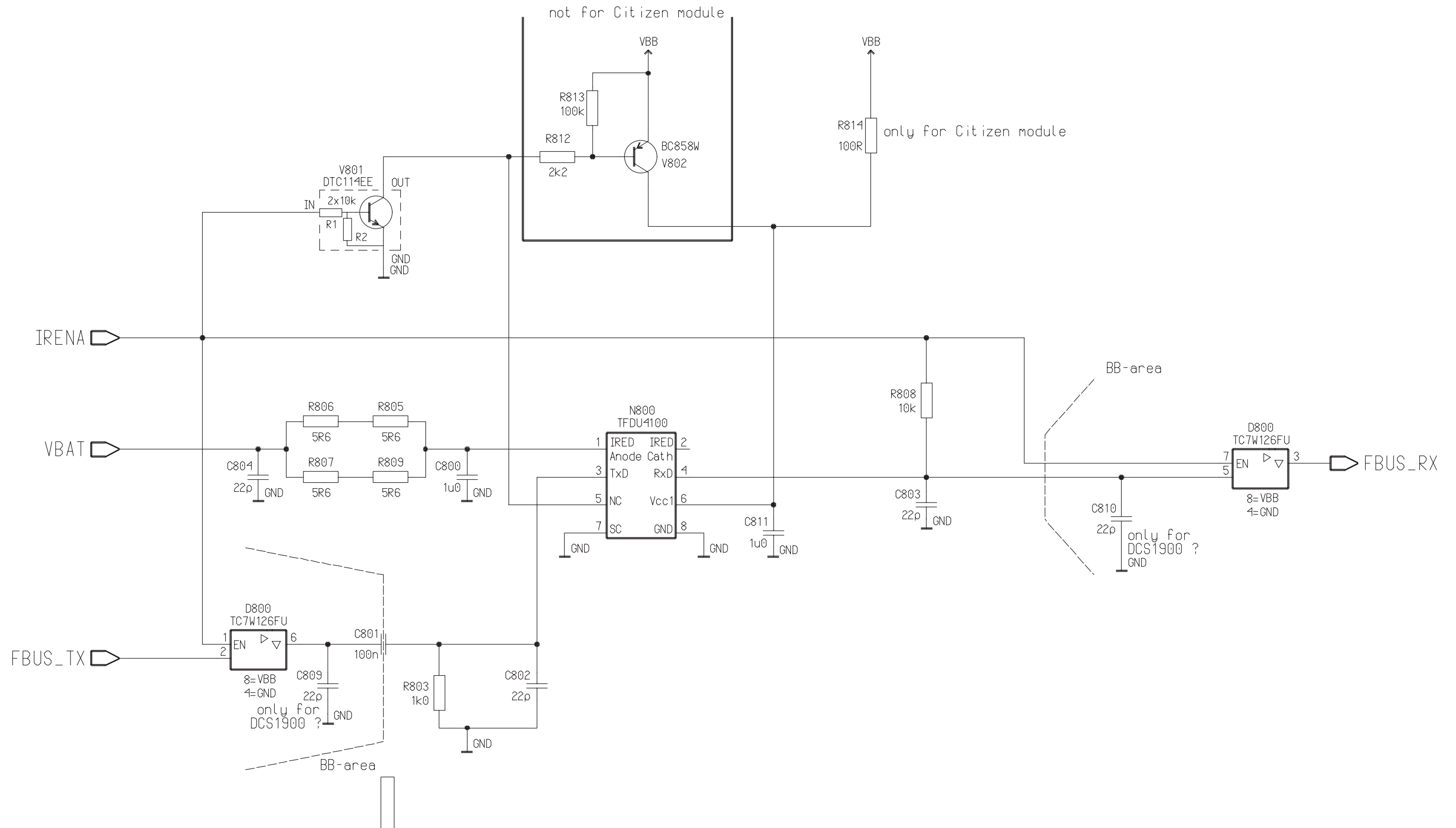

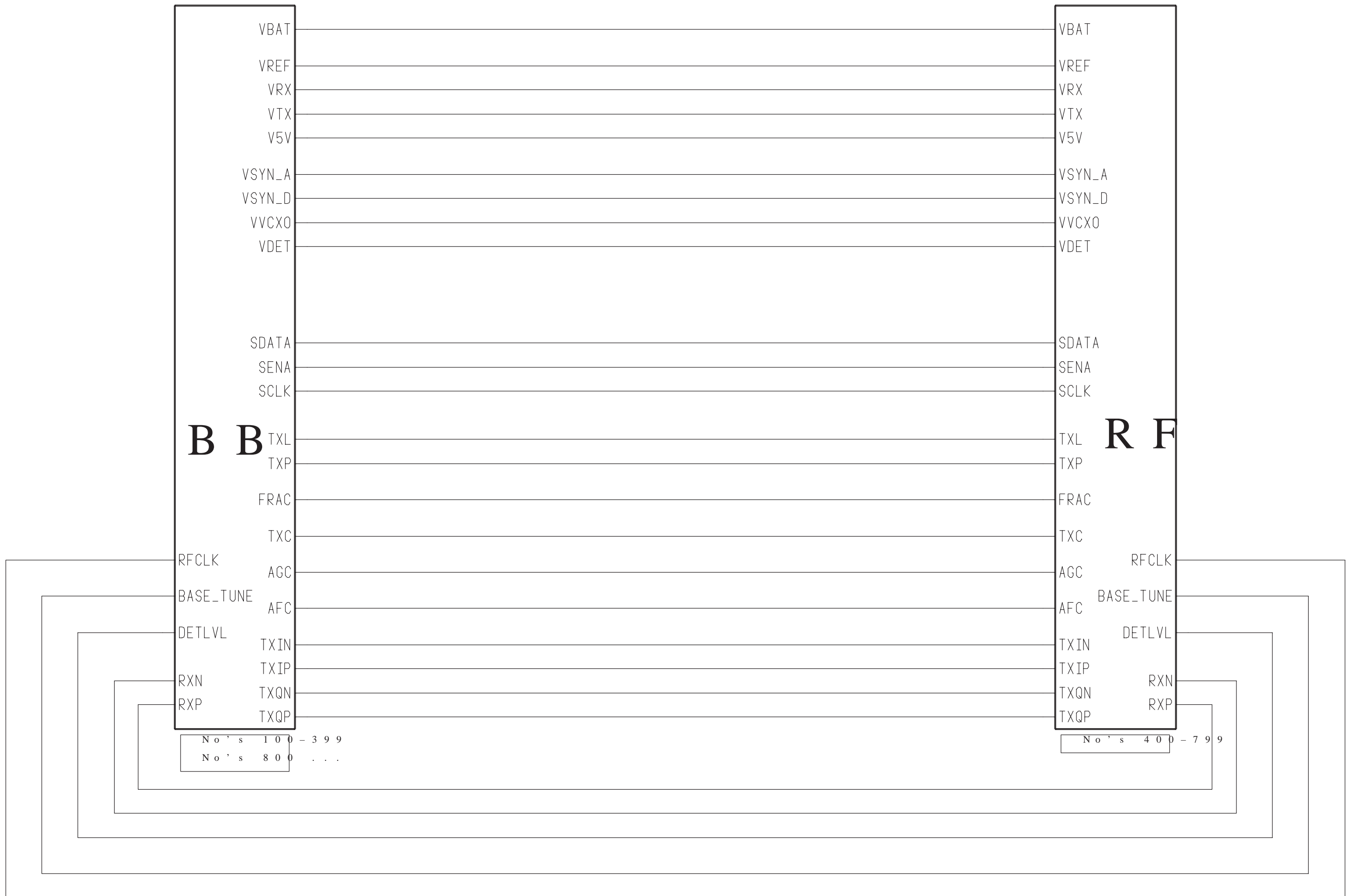

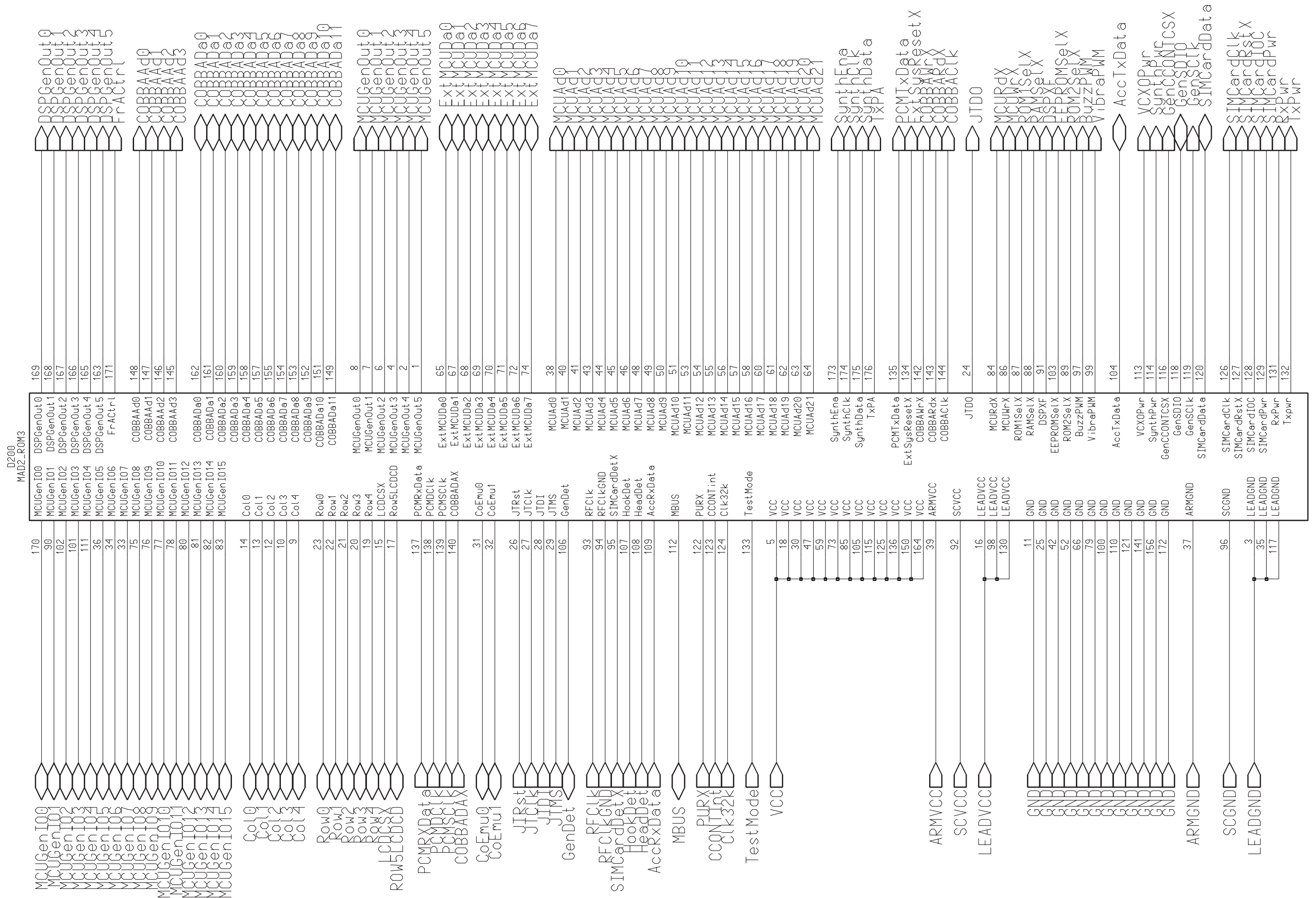

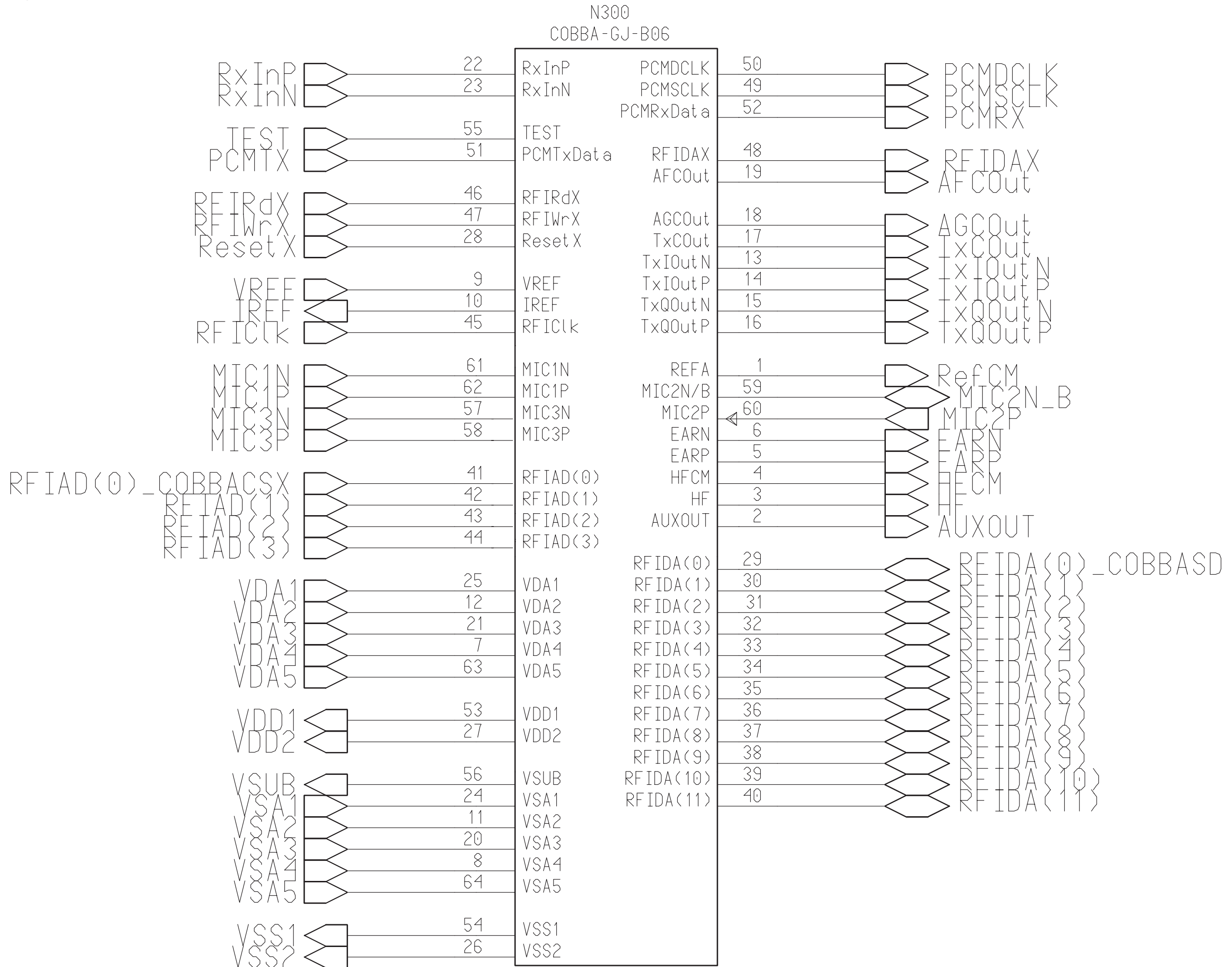

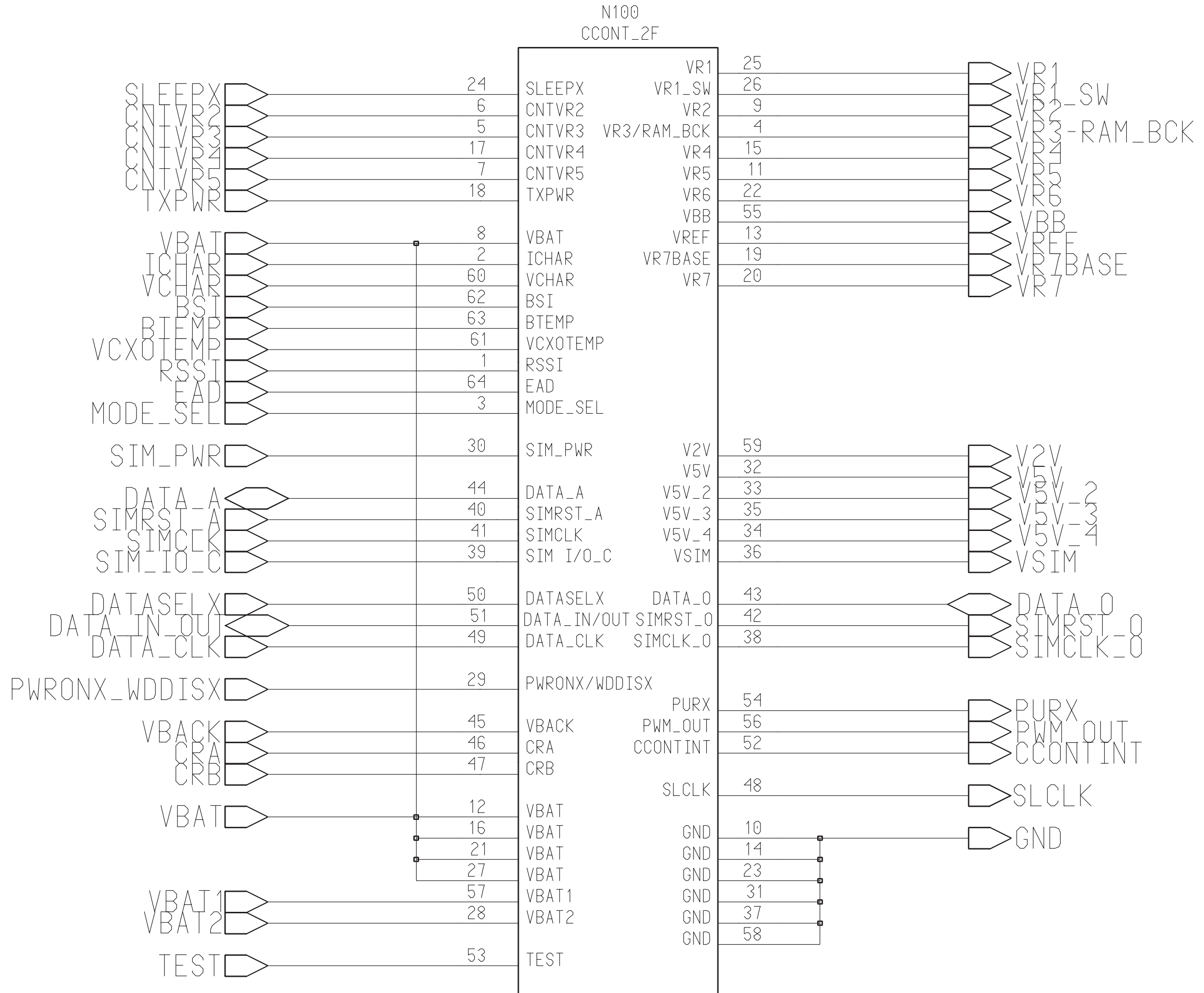



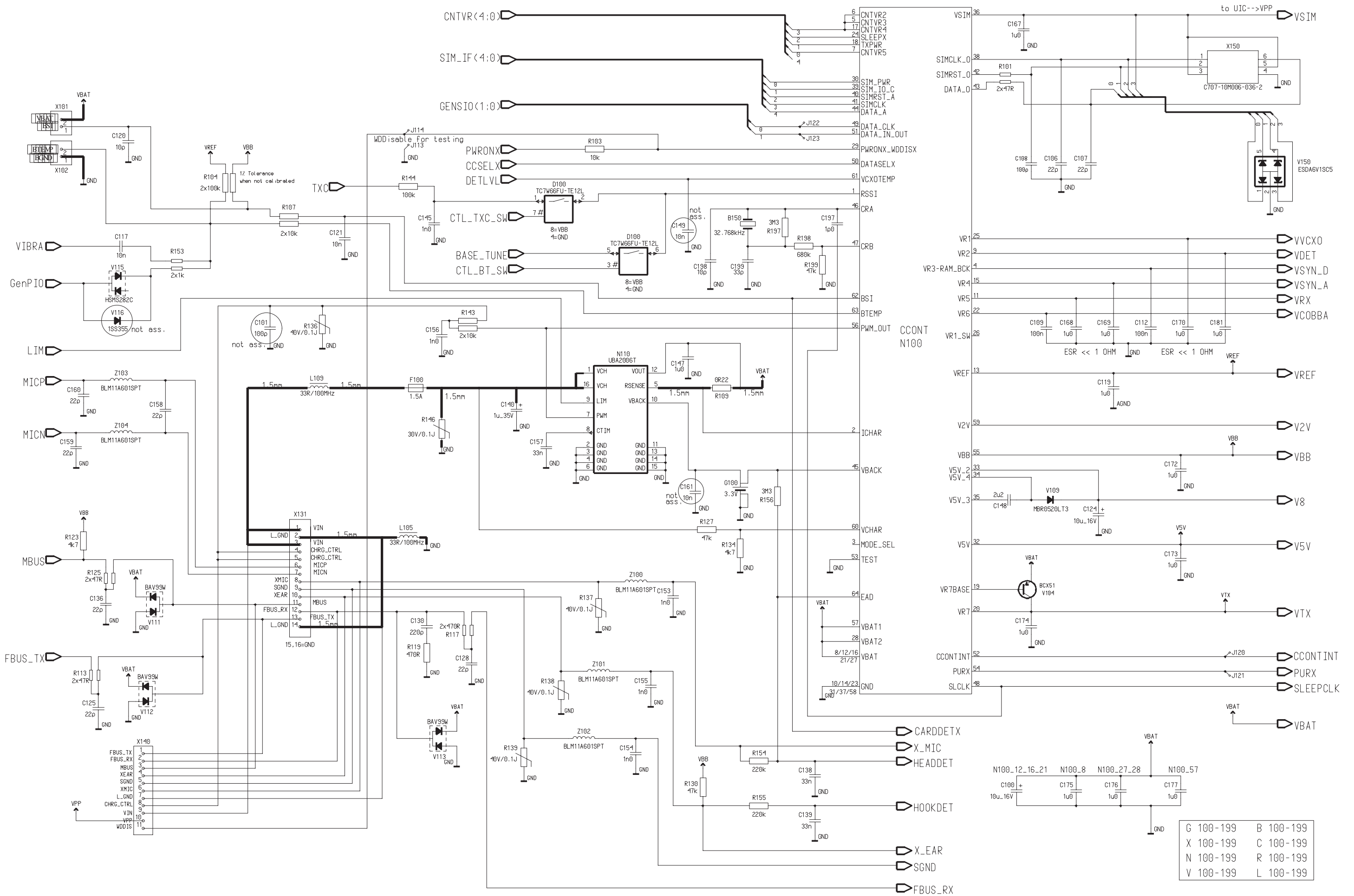

G 100-199	B 100-199
X 100-199	C 100-199
N 100-199	R 100-199
V 100-199	L 100-199

